



Ilur

The “sail and oar” star



Clinker Ilur built by Icarai

Ilur was designed after Aber, in order to get a larger boat, able to family day sailing. It can be used for fishing and even coastal cruising! Two Ilur have been to Ile of Sein, at the extreme West of France, one of the worst place to go with tremendous tides and the worst sea conditions. However, do not consider this as an invitation to go there ! Length was increased by 20 cm only, but Ilur is mostly wider and higher, with a generous freeboard. This makes a very different boat, with good seakeeping ability, but still in the “sail and oar” spirit. Its superior quality makes Ilur my best-seller plan (with nearly a thousand copies sold). It has been built in many places, from the very heart of Alps, to Pacific islands!



The light clinker version is easy to row

Ilur is built with a strip planked or a plywood clinker hull. In both cases, Ilur is very close to a traditional construction (steam bent or laminated frames, timber sheerstrakes, seat risers...) and this gives the boat a high

level of authenticity.

Ilur is now fitted with a pivoting centreboard. The case is lowered and is not cumbersome. The oars may be stowed either above or under floorboards in order to free space when under sail. Ilur is a very friendly boat able to welcome 4 or 5 persons.



A lot of space, thanks to the lowered centreboard case

Three rig options are offered. The standing lug sail (misainier in French) is the most popular. It is simple and efficient (but be careful not to haul taut the sheet). The sail is tacked between mast and stem et remains always on the same side of mast. When tacking, the helmsman has just to take the sheet from one thumb cleat to the other side. There is no boom and this is comfortable for fishing or family sailing. It is recommended to have a pole when running.



Well tuned, this strip planked Ilur has good windward ability.

The lug sloop (next page), is closer to modern rigs, with a mainsail and a jib, and gives improved performances. It is possible to shift the mast forward and have to boat rigged as a balanced lug with a moderate size sail. This is useful for single-handed sailing or in case of strong wind.



The last option is the balanced lug, the sail being fitted with a boom. This rig is a good choice for river as well as single-handed sailing as there is no need to use a pole. It is also more powerful than the standing lug.



A boat for the home builder

Ilur is not an “instant boat” you can built within a few week-ends. The aim of the designer was to have an exquisite traditional boat which may be built by any people able to make something with their hands.

Plan package is very complete and detailed. Dimensioned drawings for stations, stem and transom profile (including bevels) allow construction without any lofting.

To make construction easier, optional full size patterns on mylar (polyester film) may also be used. For the clinker

version, they give the profile of each strakes to be cut directly at final dimension. The only adjustment is at ends.

For the clinker version, it is also possible to buy a plywood kit with all parts cut on a NC machine. This results in better quality and a big saving of working time. Professional are now always building that way.

The average time to build Ilur from a kit is 500 hours. A perfect strip planked hull may take much more.

It is also possible to build the clinker version with timber instead of plywood. In that case, there is 15 strakes per side instead of 10. For more information, ask the designer.



Of course Ilur is a trailerable boat and the simple rig is raised in a few minutes. She is very easy to launch and recover even by a single person.



Launching of an Ilur built by Icarai in Cherbourg

Ilur builders and kits suppliers:

France: Icarai:

Centre d'activités, 4 avenue Louis Lumière
50100 Cherbourg - phone: 33 2 33 41 38 91
e-mail : nvivier@icarai.fr - Internet : www.icarai.fr

USA: Clint Chase Boat Builder:

25 Deblois Street
Portland, Maine - phone: 1 207.879.7782
clint@clintchaseboatbuilder.com
www.cncboatkits.com

7, avenue des Courtils – 44380 Pornichet - tél : 02 28 54 97 86

E-mail : francois@vivier.info - www.francois.vivier.info

François Vivier Architecte Naval – SARL au capital de 8 000 € - Siren : 451 456 669 RCS Saint Nazaire



Ilur

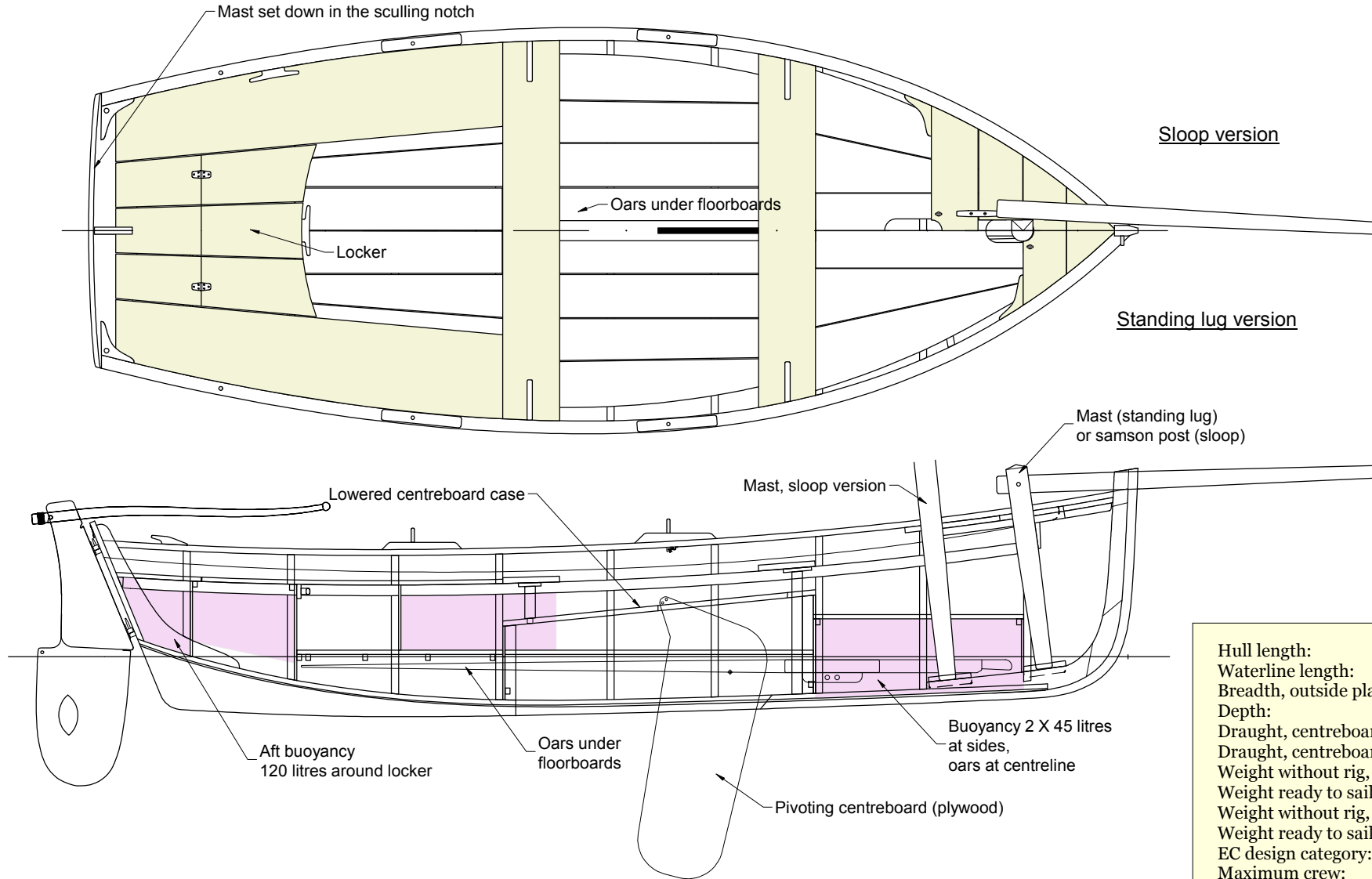

Hull length:	4.44 m
Waterline length:	4.10 m
Breadth, outside planking:	1.70 m
Depth:	0.68 m
Draught, centreboard up:	0.25 m
Draught, centreboard down:	0.86 m
Weight without rig, clinker:	245 kg
Weight ready to sail, clinker:	300 kg
Weight without rig, strip:	290 kg
Weight ready to sail, strip:	345 kg
EC design category:	C / D
Maximum crew:	3 / 5

Balanced lug

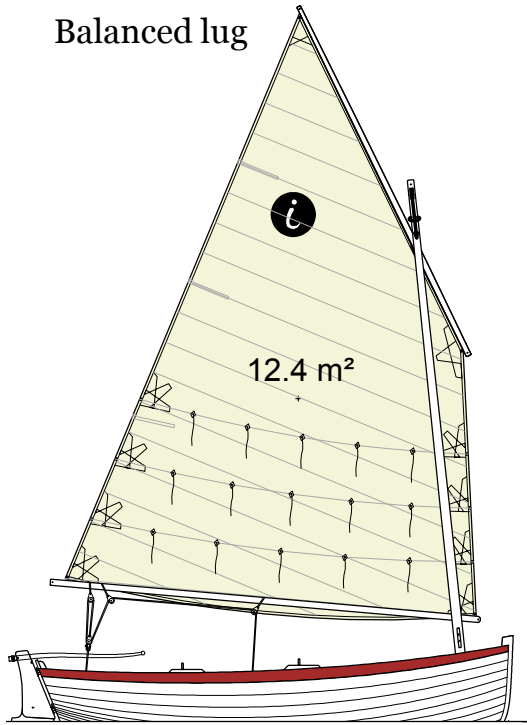

"Misainier"
Standing lug

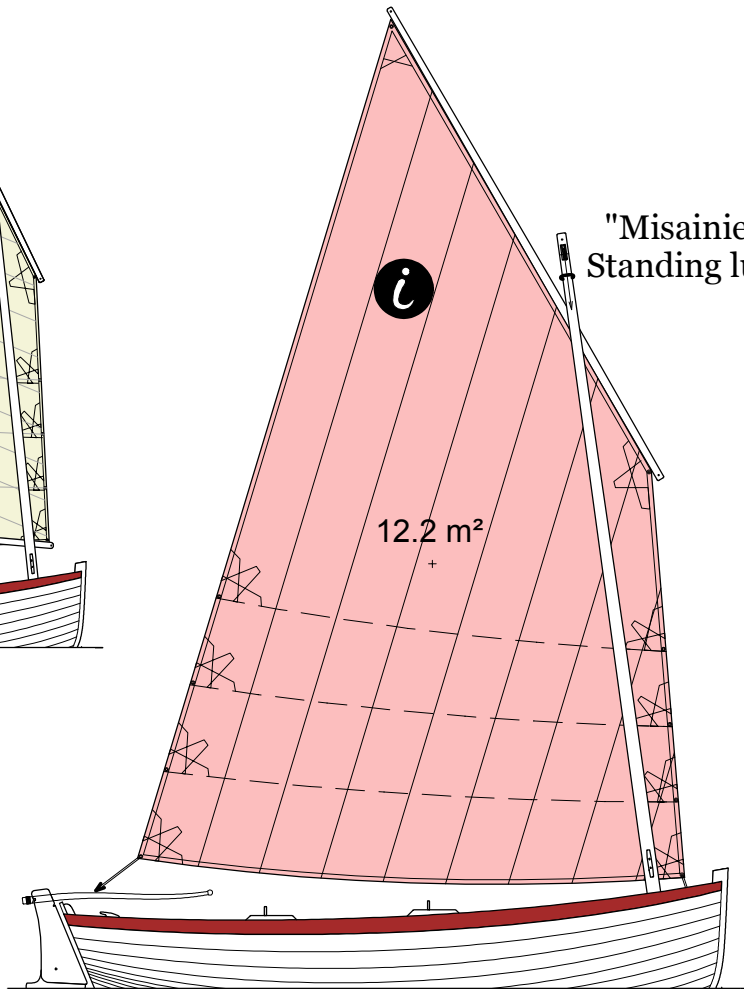

Lug sloop

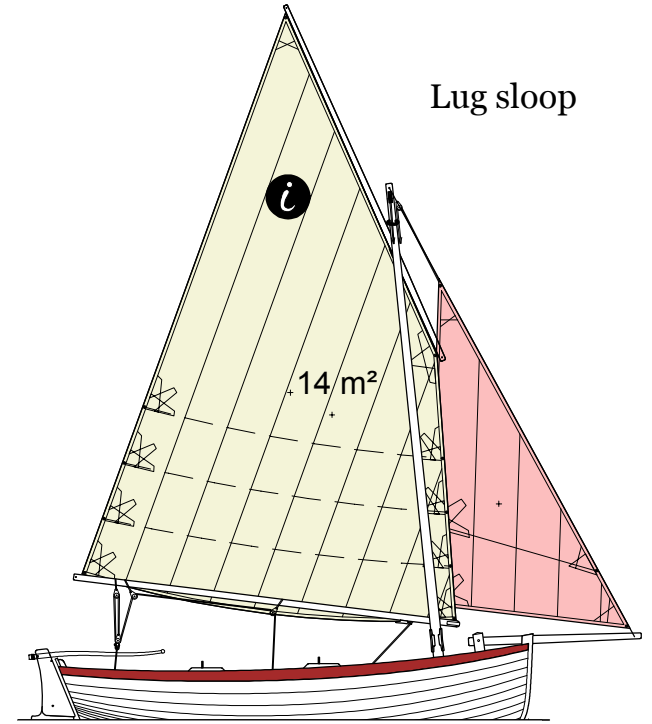

Lug sloop
with mast
moved forward

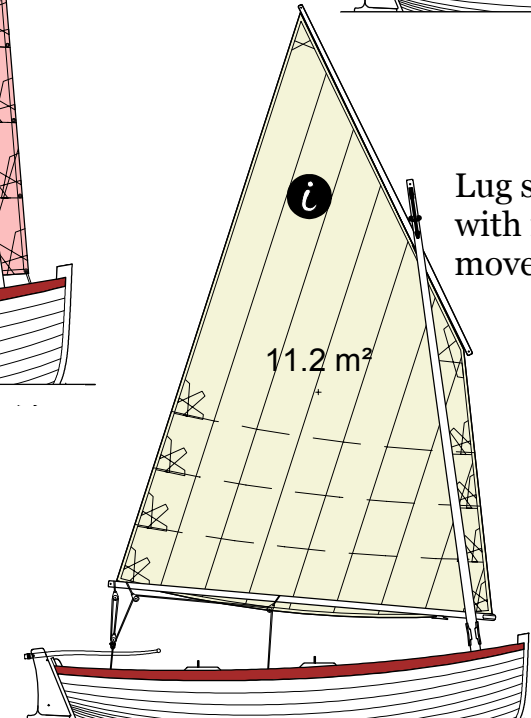

Ilur

Rig versions
Scale 1/50 et 1/70